



MTN/1100S Series

Low profile side entry industrial accelerometer for restricted access installations

Applications

- Data-collector
- Heavy industry
- Paper machinery

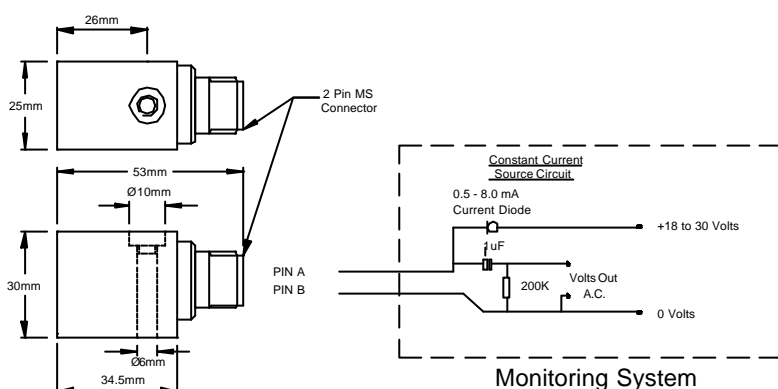

Technical Specification

Sensitivity	100 mV/g $\pm 10\%$ nominal at 80 Hz
Frequency Response	2 Hz to 10 kHz $\pm 5\%$ (-3 dB at 0.8 Hz)
Mounted Base Resonance	18 kHz (nominal)
Isolation	Base isolated
Dynamic Range	$\pm 80g$
Transverse Sensitivity	Less than 5%
Electrical Noise	0.1 mg max
Current Range	0.5 mA to 8 mA
Temperature Range	-55 to 140 °C
Bias Voltage	12 Volts DC (nominal)
Case Material	Stainless steel
Mounting Torque	8 Nm
Mounting Bolt Provided	M6 x 33mm long (Part no MTN/1100SM6) or 1/4"-28UNF x 33mm long (Part no MTN/1100S)
Weight	170 gms (nominal)
Sealing	IP67
Maximum Cable Length	1000 metres
Mating Connector	MTN/MH002
Options	Mounting cable assemblies and other sensitivities.